

Part #	Qty	Description
2	2	Couple
3	2	Arm
4	1	Backbone
5	4	Large Gusset
6	2	Box Cap

		REVISIONS		DATE	APPROVED
ZONE	REV.	DESCRIPTION			

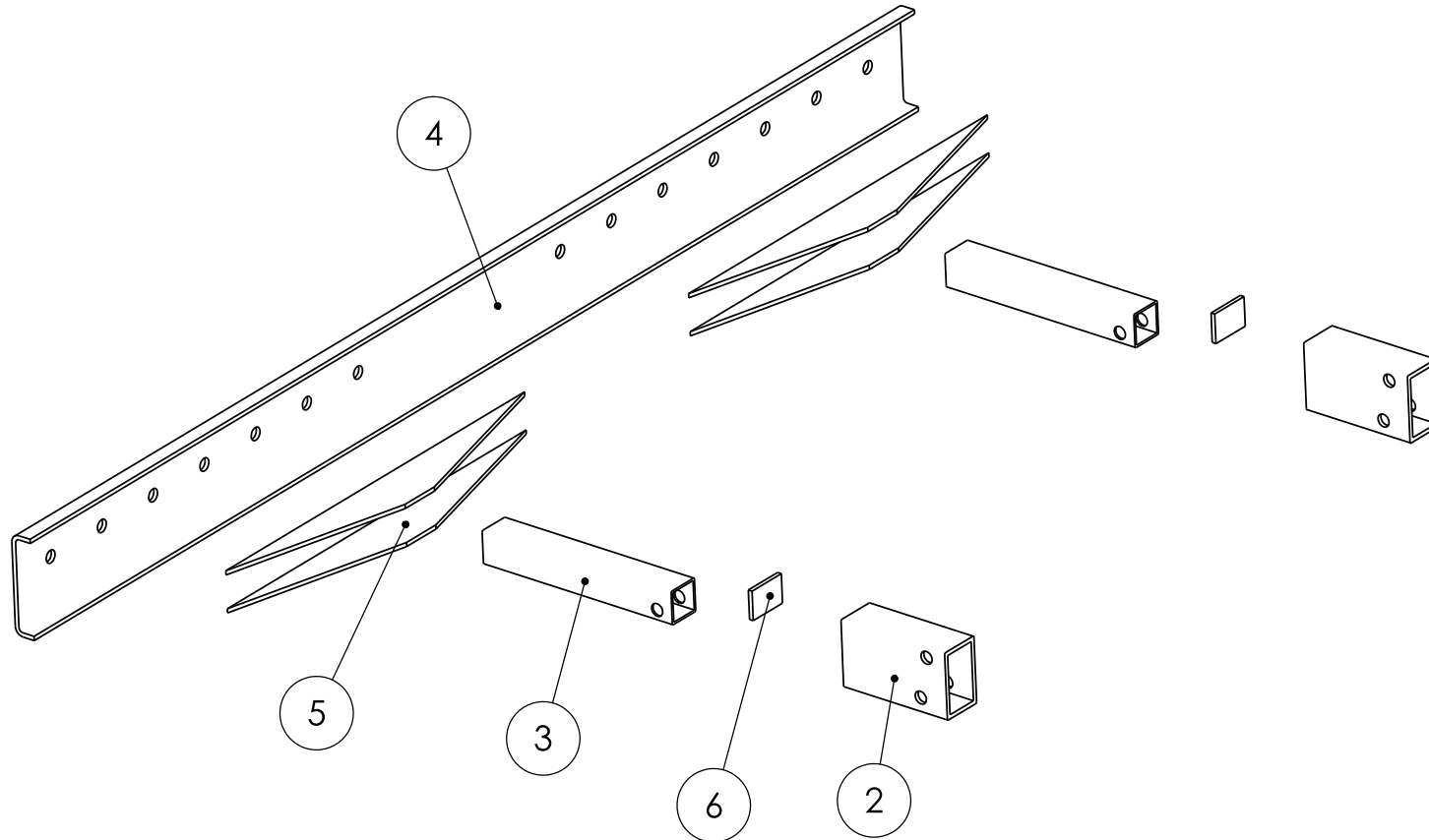

DIMENSIONS ARE IN INCHES		NAME	DATE	HDC, Inc.
TOLERANCES:		DRAWN	???	
FRACTIONAL ±		CHECKED		A-Bumper Frame DODGE
ANGULAR: MACH ± BEND ±		ENG APPR.		
TWO PLACE DECIMAL ±		MFG APPR.		
THREE PLACE DECIMAL ±		Q.A.		
MATERIAL	--	COMMENTS:		
FINISH	--			
DO NOT SCALE DRAWING				
SIZE	DWG. NO.	REV.		
SCALE: 1:10	WEIGHT:	SHEET 1 OF 10		

.....
 THE INFORMATION CONTAINED IN THIS DRAWING IS THE SOLE PROPERTY OF HDC, Inc. ANY REPRODUCTION IN PART OR AS A WHOLE WITHOUT THE WRITTEN PERMISSION OF HDC, Inc. IS PROHIBITED.

		REVISIONS		
ZONE	REV.	DESCRIPTION	DATE	APPROVED

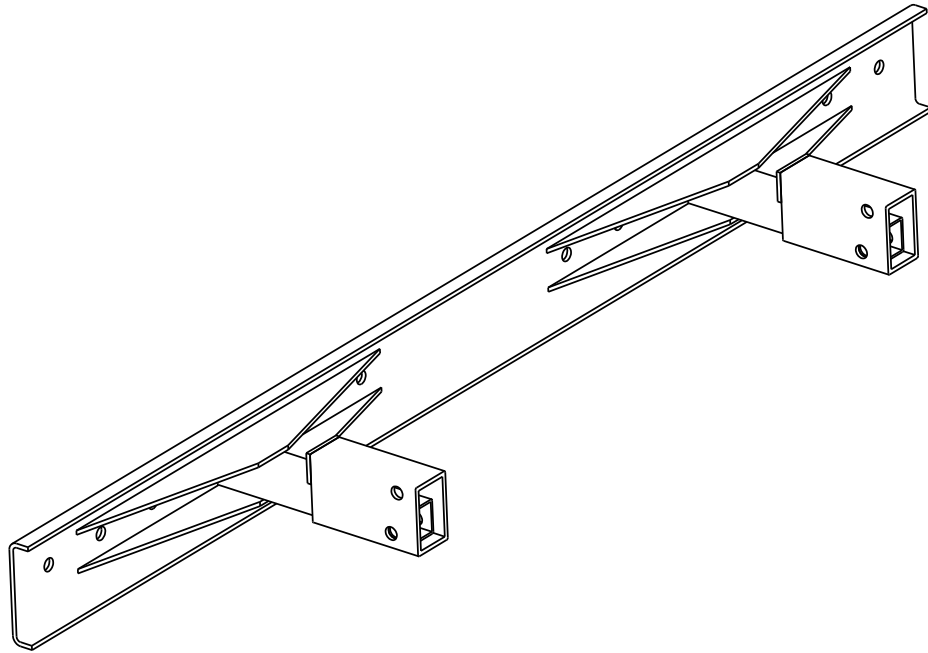

.....
 THE INFORMATION CONTAINED IN THIS DRAWING IS THE SOLE PROPERTY OF HDC, Inc. ANY REPRODUCTION IN PART OR AS A WHOLE WITHOUT THE WRITTEN PERMISSION OF HDC, Inc. IS PROHIBITED.

DIMENSIONS ARE IN INCHES	
TOLERANCES:	
FRACTIONAL ±	
ANGULAR: MACH ±	BEND ±
TWO PLACE DECIMAL ±	
THREE PLACE DECIMAL ±	
MATERIAL	--
FINISH	--
DO NOT SCALE DRAWING	

	NAME	DATE
DRAWN	???	??/??/????
CHECKED		
ENG APPR.		
MFG APPR.		
Q.A.		
COMMENTS:		

HDC, Inc.		
ABumper Frame DODGE		
SIZE	DWG. NO.	REV.
•		
SCALE:1:10	WEIGHT:	SHEET 2 OF 10

		REVISIONS			
ZONE	REV.	DESCRIPTION	DATE	APPROVED	

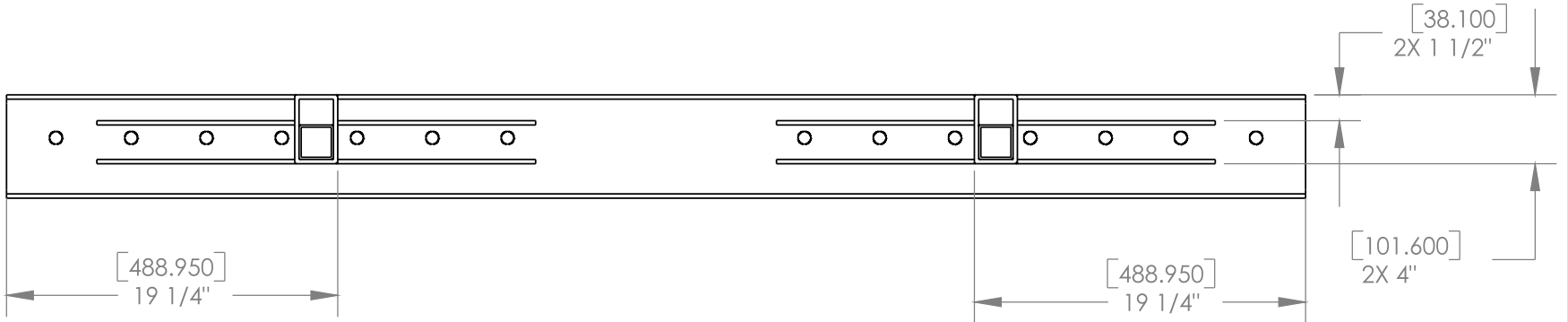

.....
 THE INFORMATION CONTAINED IN THIS DRAWING IS THE SOLE PROPERTY OF HDC, Inc. ANY REPRODUCTION IN PART OR AS A WHOLE WITHOUT THE WRITTEN PERMISSION OF HDC, Inc. IS PROHIBITED.

DIMENSIONS ARE IN INCHES
 TOLERANCES:
 FRACTIONAL ±
 ANGULAR: MACH ± BEND ±
 TWO PLACE DECIMAL ±
 THREE PLACE DECIMAL ±

MATERIAL --
 FINISH --
 DO NOT SCALE DRAWING

	NAME	DATE
DRAWN	???	??/??/????
CHECKED		
ENG APPR.		
MFG APPR.		
Q.A.		
COMMENTS:		

HDC, Inc.

**ABumper Frame
DODGE**

SIZE	DWG. NO.	REV.
•		
SCALE:1:10	WEIGHT:	SHEET 3 OF 10

ZONE		REV.	REVISIONS	DATE	APPROVED
			DESCRIPTION		

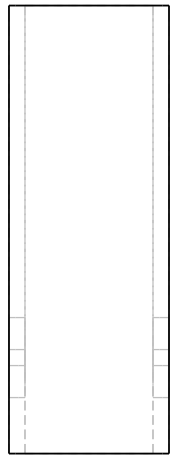
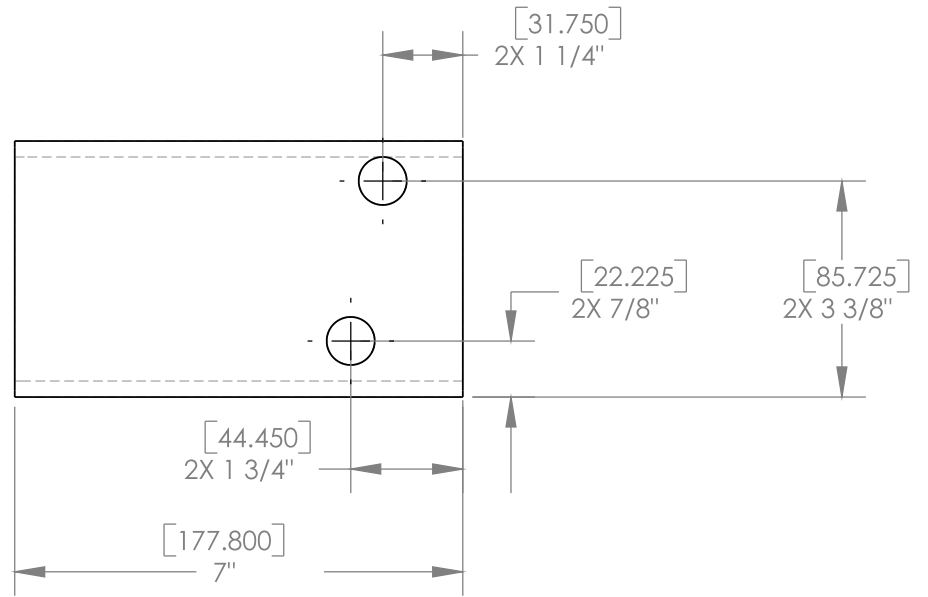
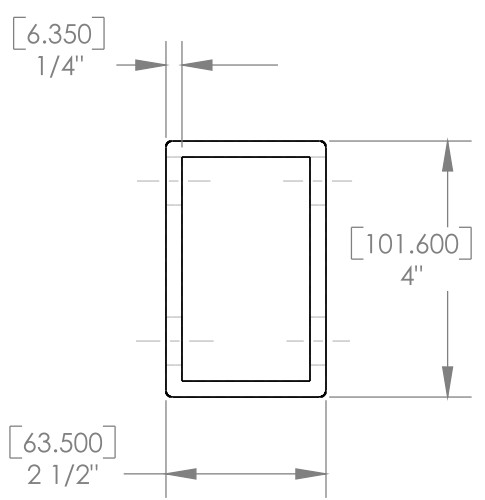

.....
 THE INFORMATION CONTAINED IN THIS DRAWING IS THE SOLE PROPERTY OF HDC, Inc. ANY REPRODUCTION IN PART OR AS A WHOLE WITHOUT THE WRITTEN PERMISSION OF HDC, Inc. IS PROHIBITED.

DIMENSIONS ARE IN INCHES		NAME	DATE	HDC, Inc.
TOLERANCES:		DRAWN	???	
FRACTIONAL ±		CHECKED		Couple
ANGULAR: MACH ± BEND ±		ENG APPR.		
TWO PLACE DECIMAL ±		MFG APPR.		
THREE PLACE DECIMAL ±		Q.A.		
MATERIAL	1/4" Structural Steel Box Tubing	COMMENTS:		SCALE: 1:3
FINISH	--			
DO NOT SCALE DRAWING				REV.
				SHEET 4 OF 10

ZONE		REV.	REVISIONS	DATE	APPROVED
			DESCRIPTION		

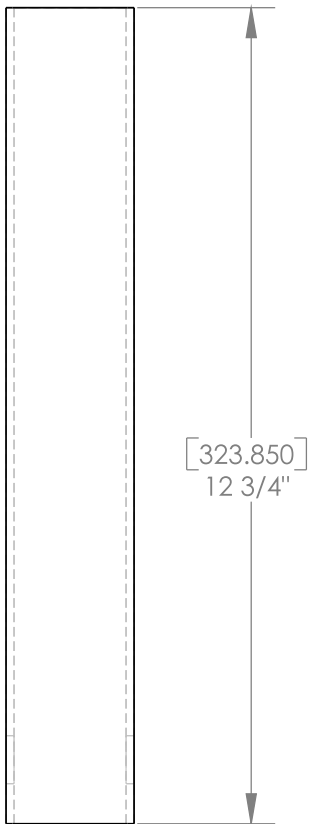
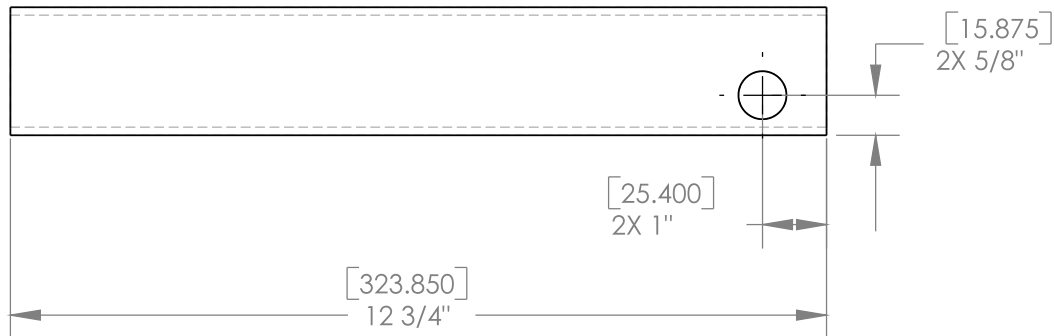
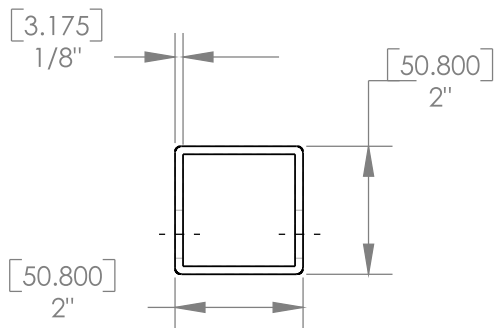

.....
 THE INFORMATION CONTAINED IN THIS DRAWING IS THE SOLE PROPERTY OF HDC, Inc. ANY REPRODUCTION IN PART OR AS A WHOLE WITHOUT THE WRITTEN PERMISSION OF HDC, Inc. IS PROHIBITED.

DIMENSIONS ARE IN INCHES		NAME	DATE
TOLERANCES:		DRAWN	???
FRACTIONAL ±		??/??/????	
ANGULAR: MACH ± BEND ±		CHECKED	
TWO PLACE DECIMAL ±		ENG APPR.	
THREE PLACE DECIMAL ±		MFG APPR.	
MATERIAL		Q.A.	
1/8" Structural Steel Box Tubing		COMMENTS:	
FINISH --			
DO NOT SCALE DRAWING			

HDC, Inc.

Arm

SIZE	DWG. NO.	REV.
•		
SCALE: 1:3	WEIGHT:	SHEET 5 OF 10

ZONE		REV.	REVISIONS	DATE	APPROVED
			DESCRIPTION		

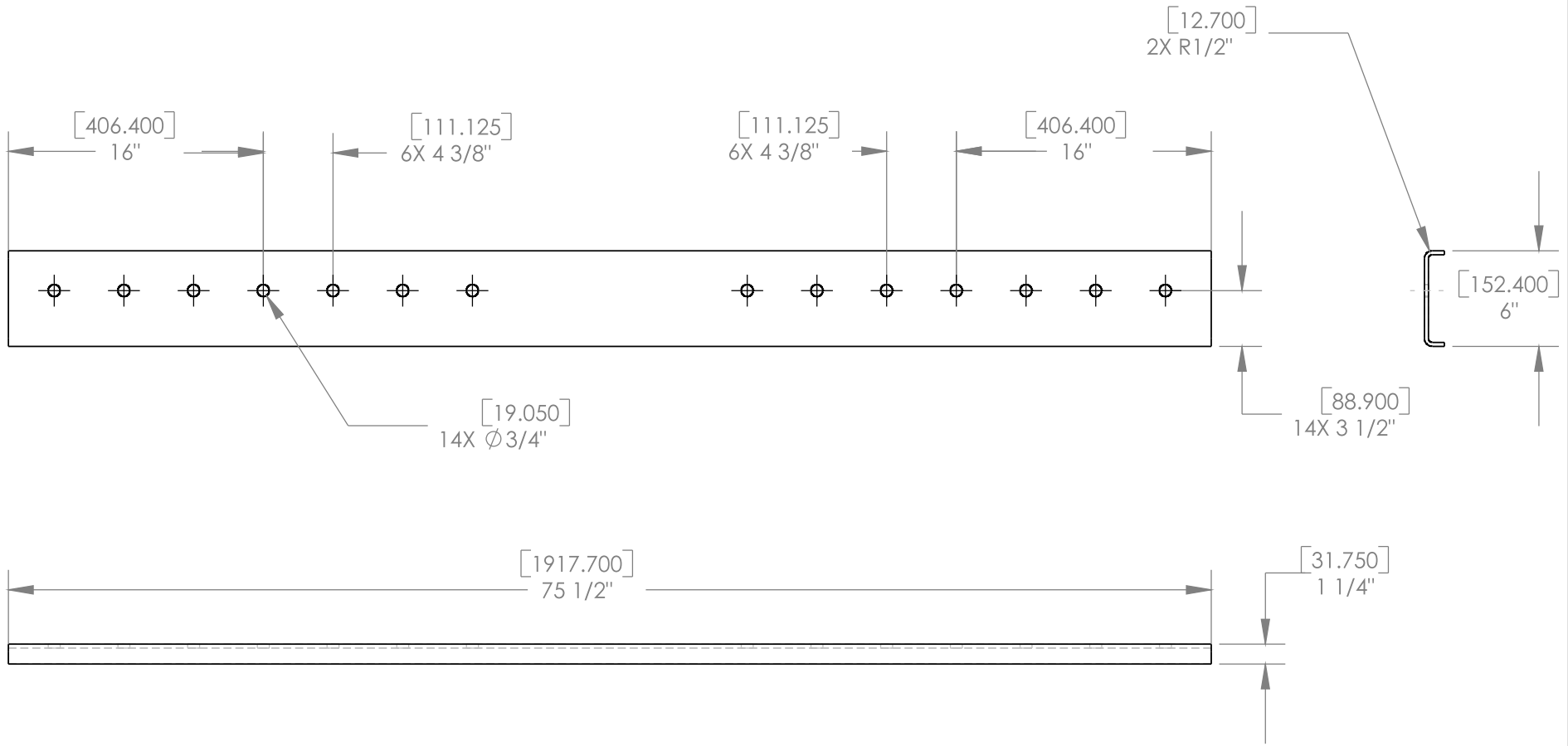

NOTE: 1/4" Thickness

.....
 THE INFORMATION CONTAINED IN THIS DRAWING IS THE SOLE PROPERTY OF HDC, Inc. ANY REPRODUCTION IN PART OR AS A WHOLE WITHOUT THE WRITTEN PERMISSION OF HDC, Inc. IS PROHIBITED.

DIMENSIONS ARE IN INCHES		NAME	DATE
TOLERANCES:		DRAWN	???
FRACTIONAL ±		CHECKED	??/??/????
ANGULAR: MACH ± BEND ±		ENG APPR.	
TWO PLACE DECIMAL ±		MFG APPR.	
THREE PLACE DECIMAL ±		Q.A.	
MATERIAL		COMMENTS:	
1/4" Structural Steel Channel			
FINISH			
--			
DO NOT SCALE DRAWING			

HDC, Inc.		
Backbone		
SIZE	DWG. NO.	REV.
•		
SCALE:1:10	WEIGHT:	SHEET 6 OF 10

		REVISIONS			
ZONE	REV.	DESCRIPTION	DATE	APPROVED	

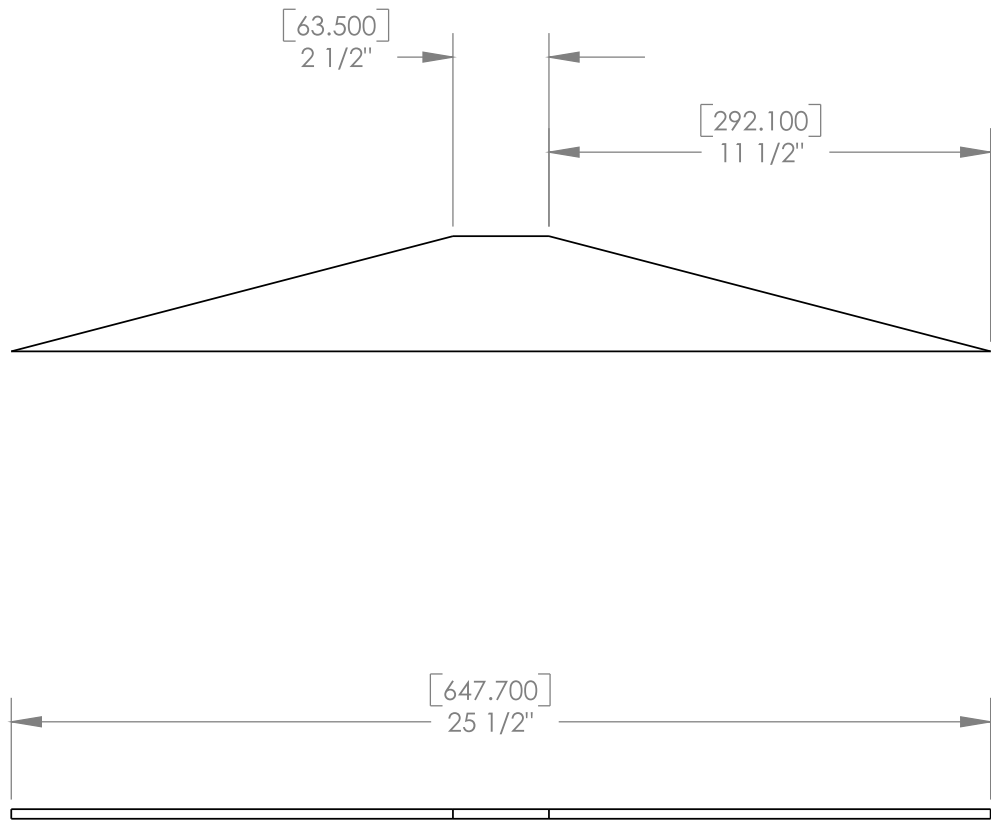

.....
 THE INFORMATION CONTAINED IN THIS DRAWING IS THE SOLE PROPERTY OF HDC, Inc. ANY REPRODUCTION IN PART OR AS A WHOLE WITHOUT THE WRITTEN PERMISSION OF HDC, Inc. IS PROHIBITED.

DIMENSIONS ARE IN INCHES
 TOLERANCES:
 FRACTIONAL ±
 ANGULAR: MACH ± BEND ±
 TWO PLACE DECIMAL ±
 THREE PLACE DECIMAL ±

MATERIAL
 1/4" Flat Steel Stock

FINISH --

DO NOT SCALE DRAWING

	NAME	DATE
DRAWN	???	??/??/????
CHECKED		
ENG APPR.		
MFG APPR.		
Q.A.		
COMMENTS:		

HDC, Inc.

Large Gusset

SIZE	DWG. NO.	REV.
•		
SCALE: 1:5	WEIGHT:	SHEET 7 OF 10

REVISIONS			
ZONE	REV.	DESCRIPTION	DATE

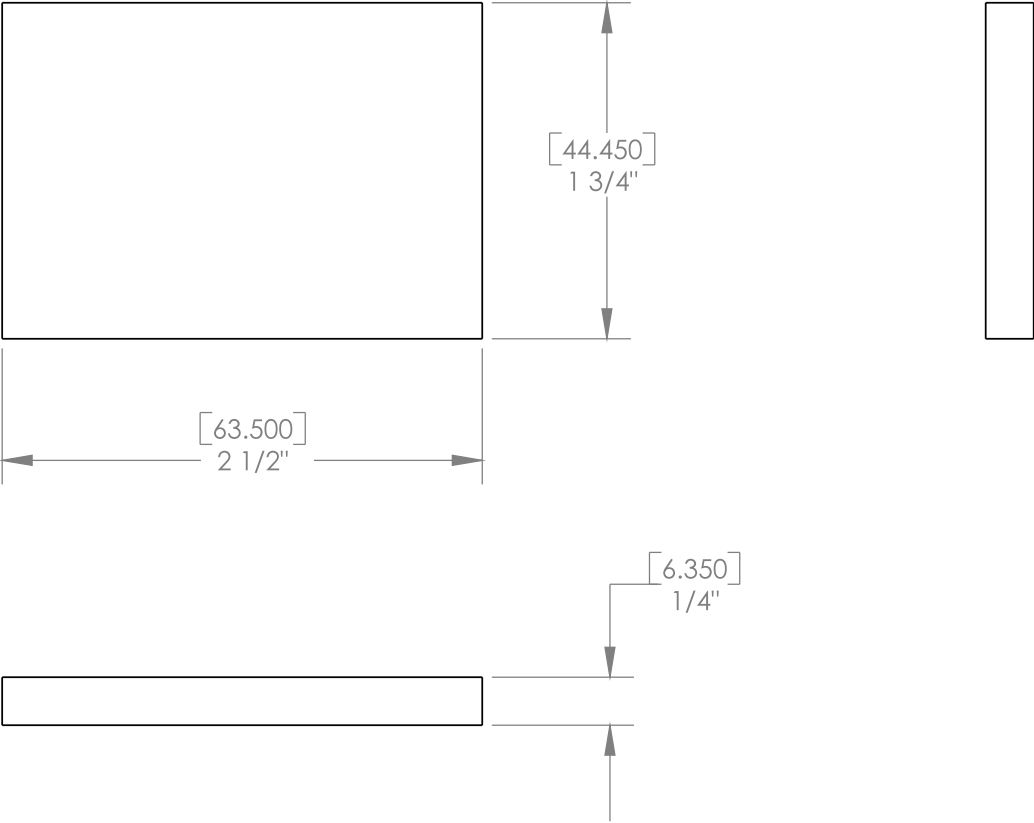

.....
 THE INFORMATION CONTAINED IN THIS DRAWING IS THE SOLE PROPERTY OF HDC, Inc. ANY REPRODUCTION IN PART OR AS A WHOLE WITHOUT THE WRITTEN PERMISSION OF HDC, Inc. IS PROHIBITED.

DIMENSIONS ARE IN INCHES		NAME	DATE
TOLERANCES:		DRAWN	???
FRACTIONAL ±		CHECKED	??/??/????
ANGULAR: MACH ± BEND ±		ENG APPR.	
TWO PLACE DECIMAL ±		MFG APPR.	
THREE PLACE DECIMAL ±		Q.A.	
MATERIAL	COMMENTS:		
FINISH			
DO NOT SCALE DRAWING			

HDC, Inc.		
Box Cap		
SIZE	DWG. NO.	REV.
•		
SCALE:1:1	WEIGHT:	SHEET 8 OF 10

Part #	Qty	Description
7	14	5/8"-13 HHCS, 2.75" long, 1.55" thrd
8	14	5/8" Nylon Locking Nut
9	28	0.625" ID, 1.00" OD Washer
10	2	ABumper Pad
11	14	Metal Backing

ZONE		REV.	REVISIONS	DATE	APPROVED
			DESCRIPTION		

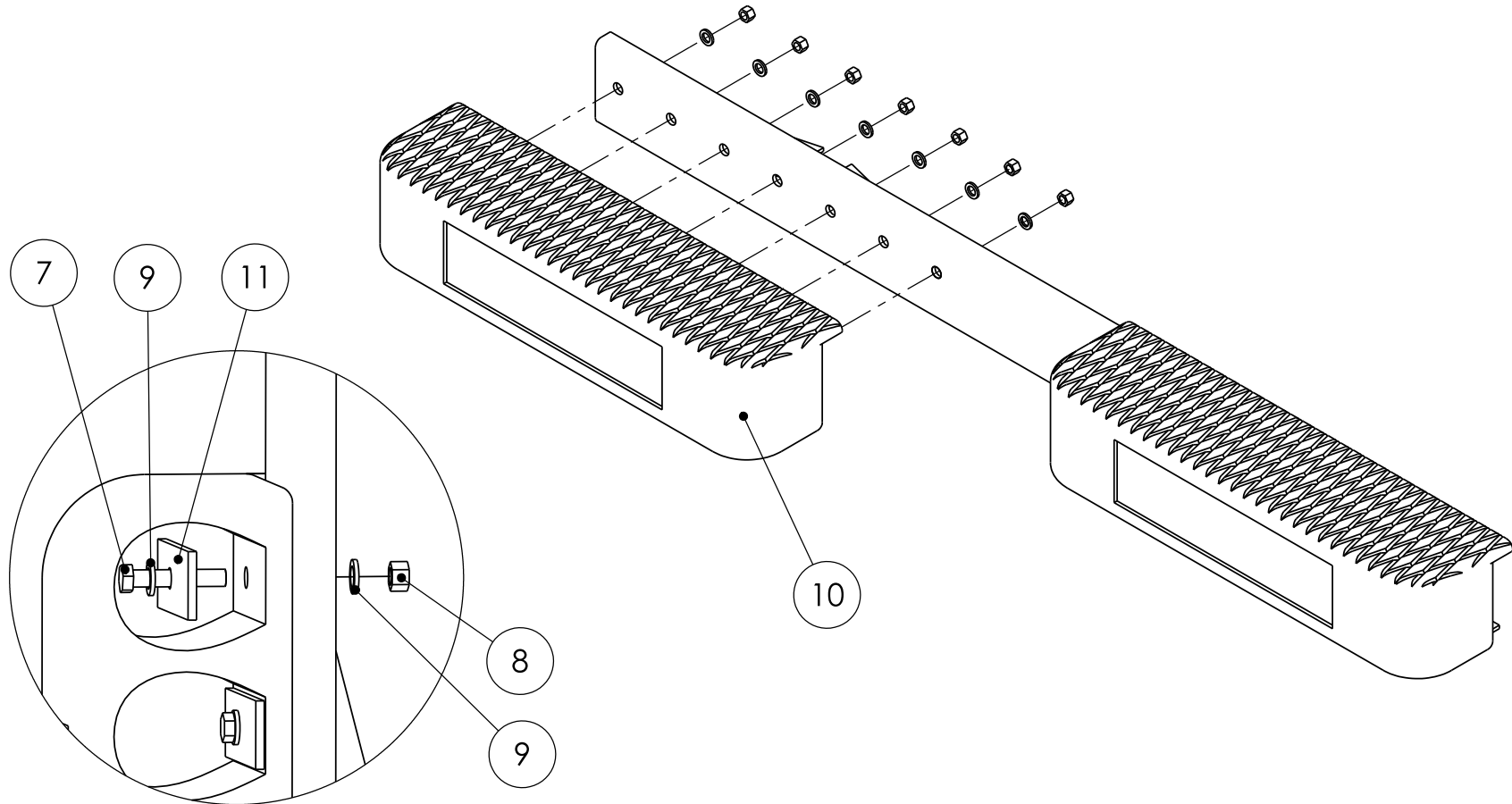

Hardware Mounting

.....
 THE INFORMATION CONTAINED IN THIS DRAWING IS THE SOLE PROPERTY OF HDC, Inc. ANY REPRODUCTION IN PART OR AS A WHOLE WITHOUT THE WRITTEN PERMISSION OF HDC, Inc. IS PROHIBITED.

DIMENSIONS ARE IN INCHES		NAME	DATE	HDC, Inc.
TOLERANCES:		DRAWN	???	
FRACTIONAL ±		CHECKED		A-Bumper Mount
ANGULAR: MACH ± BEND ±		ENG APPR.		
TWO PLACE DECIMAL ±		MFG APPR.		
THREE PLACE DECIMAL ±		Q.A.		
MATERIAL	--	COMMENTS:		SIZE DWG. NO. REV. •
FINISH	--			
DO NOT SCALE DRAWING				SCALE:1:10 WEIGHT: SHEET 9 OF 10

		REVISIONS	DATE	APPROVED
ZONE	REV.	DESCRIPTION		

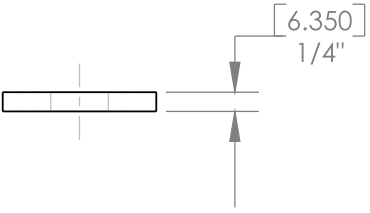
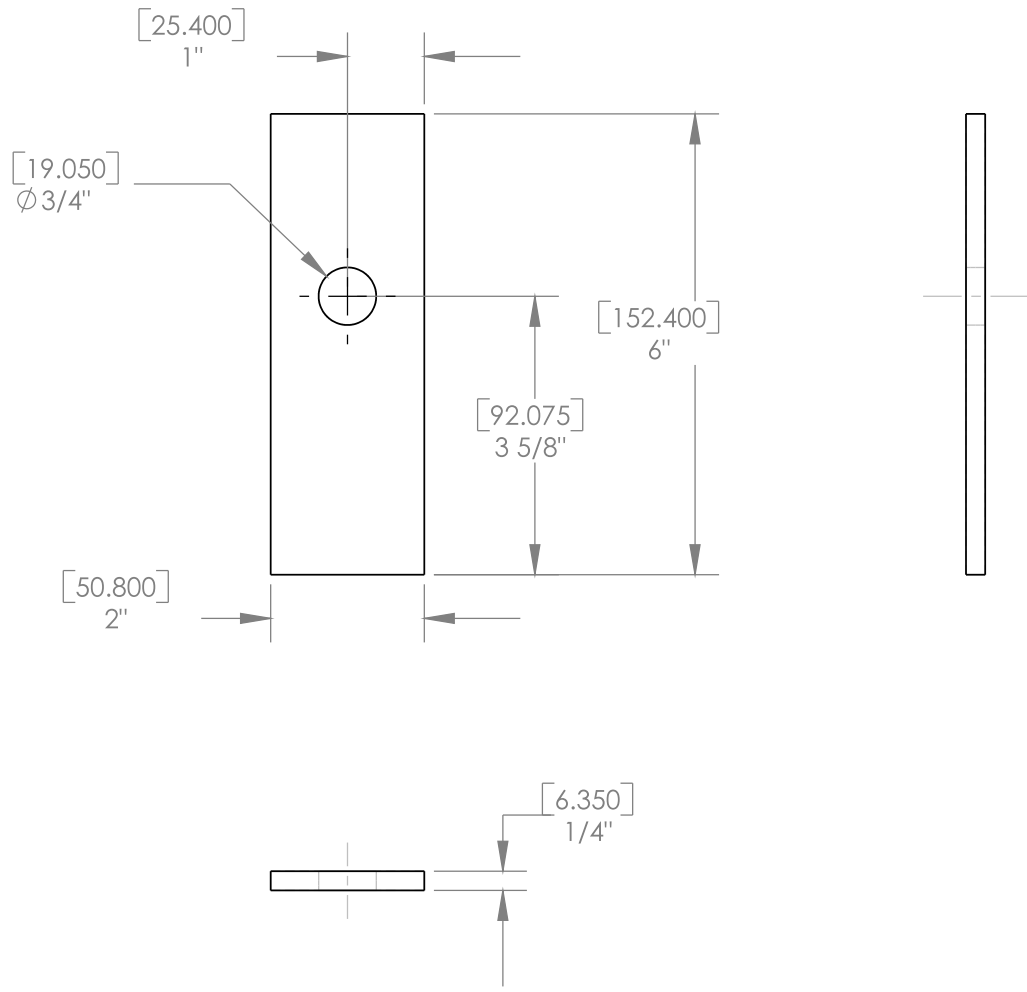

.....
 THE INFORMATION CONTAINED IN THIS DRAWING IS THE SOLE PROPERTY OF HDC, Inc. ANY REPRODUCTION IN PART OR AS A WHOLE WITHOUT THE WRITTEN PERMISSION OF HDC, Inc. IS PROHIBITED.

DIMENSIONS ARE IN INCHES		NAME	DATE
TOLERANCES:			
FRACTIONAL ±		DRAWN	CAK 09/11/2006
ANGULAR: MACH ± BEND ±		CHECKED	
TWO PLACE DECIMAL ±		ENG APPR.	
THREE PLACE DECIMAL ±		MFG APPR.	
MATERIAL		Q.A.	
FINISH		COMMENTS:	
DO NOT SCALE DRAWING			

HDC, Inc.

Metal Backing

SIZE	DWG. NO.	REV.
•		

SCALE: 1:2.5 WEIGHT: SHEET 10 OF 10