

Part #	Qty	Description
1	1	Right Frame Couple
2	1	Left Frame Couple
3	1	Left Frame Arm
4	1	Backbone
5	4	Large Gusset
6	1	Right Frame Arm
7	2	Box Cap

REVISIONS		DATE	APPROVED
ZONE	REV.	DESCRIPTION	

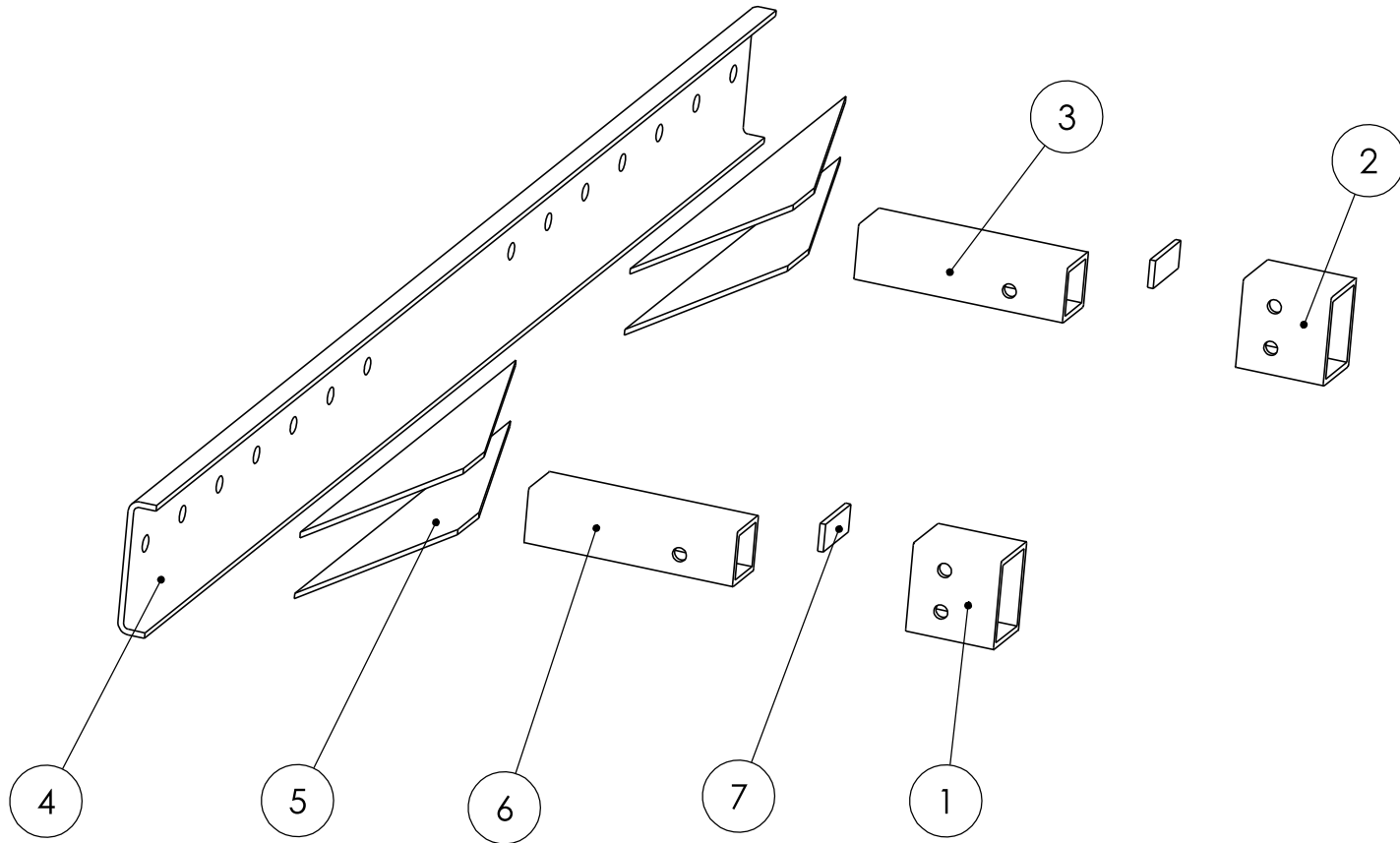

DIMENSIONS ARE IN INCHES		NAME	DATE
TOLERANCES:		DRAWN	???
FRACTIONAL ±		CHECKED	??/??/????
ANGULAR: MACH ± BEND ±		ENG APPR.	
TWO PLACE DECIMAL ±		MFG APPR.	
THREE PLACE DECIMAL ±		Q.A.	
MATERIAL	--	COMMENTS:	
FINISH	--		
DO NOT SCALE DRAWING			

.....  
 THE INFORMATION CONTAINED IN THIS DRAWING IS THE SOLE PROPERTY OF HDC, Inc. ANY REPRODUCTION IN PART OR AS A WHOLE WITHOUT THE WRITTEN PERMISSION OF HDC, Inc. IS PROHIBITED.

HDC, Inc.

**Chevrolet  
 ABumper Mount**

SIZE	DWG. NO.	REV.
•		

SCALE:1:8    WEIGHT:    SHEET 1 OF 12



REVISIONS		DATE	APPROVED
ZONE	REV.	DESCRIPTION	

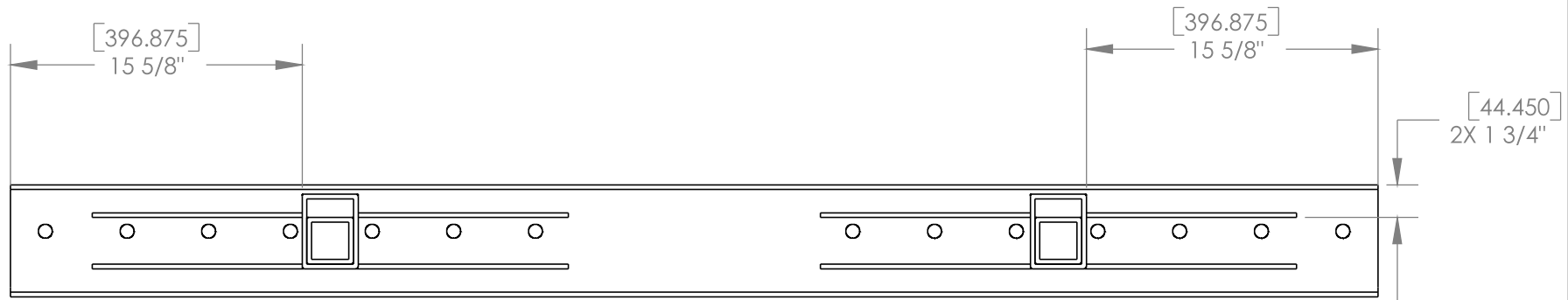

.....  
 THE INFORMATION CONTAINED IN THIS DRAWING IS THE SOLE PROPERTY OF HDC, Inc. ANY REPRODUCTION IN PART OR AS A WHOLE WITHOUT THE WRITTEN PERMISSION OF HDC, Inc. IS PROHIBITED.

DIMENSIONS ARE IN INCHES		NAME	DATE
TOLERANCES:		DRAWN	???
FRACTIONAL ±		CHECKED	??/??/????
ANGULAR: MACH ± BEND ±		ENG APPR.	
TWO PLACE DECIMAL ±		MFG APPR.	
THREE PLACE DECIMAL ±		Q.A.	
MATERIAL --		COMMENTS:	
NEXT ASSY	USED ON		
FINISH --			
APPLICATION		DO NOT SCALE DRAWING	

HDC, Inc.		
Chevrolet ABumper Mount		
SIZE	DWG. NO.	REV.
•		
SCALE:1:9	WEIGHT:	SHEET 3 OF 12

REVISIONS				
ZONE	REV.	DESCRIPTION	DATE	APPROVED

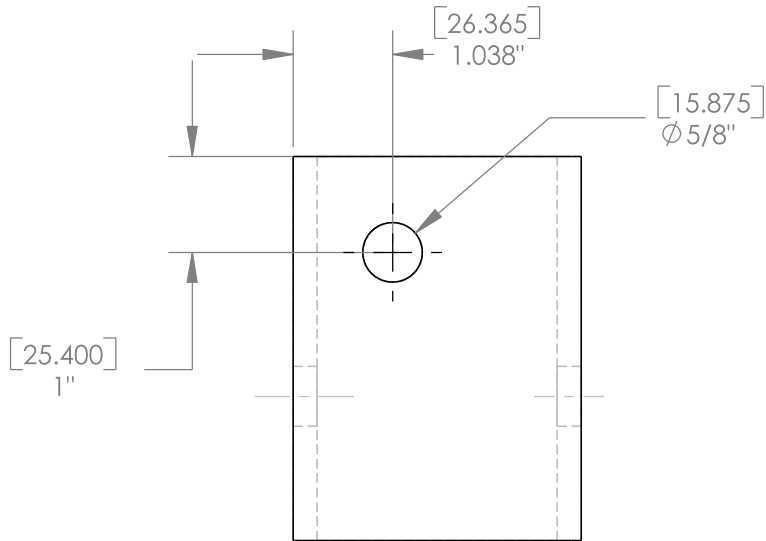
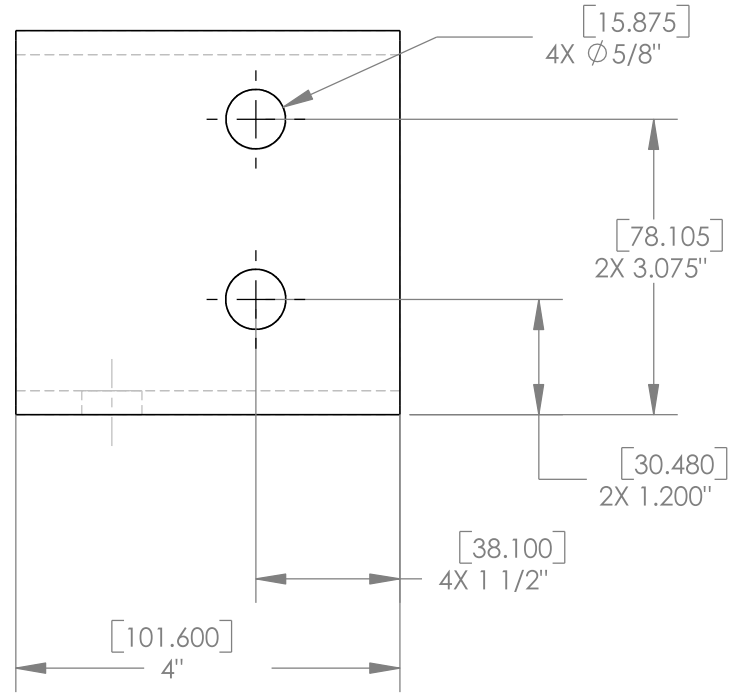
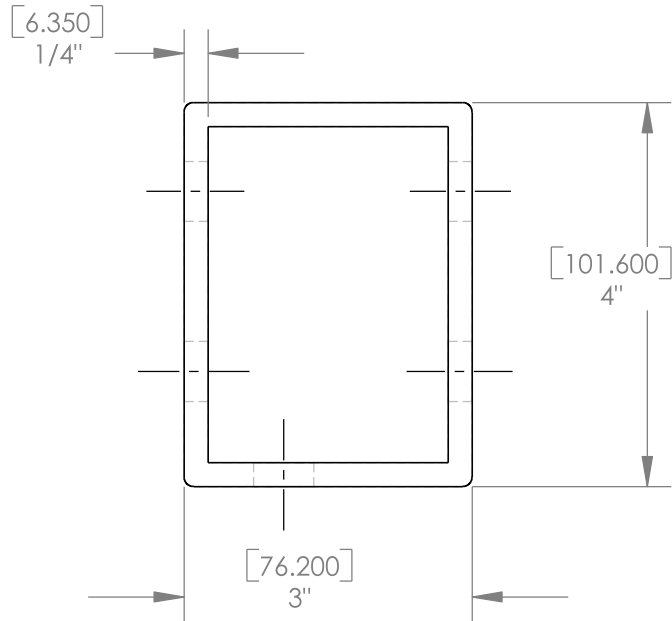

.....  
 THE INFORMATION CONTAINED IN THIS DRAWING IS THE SOLE PROPERTY OF HDC, Inc. ANY REPRODUCTION IN PART OR AS A WHOLE WITHOUT THE WRITTEN PERMISSION OF HDC, Inc. IS PROHIBITED.

DIMENSIONS ARE IN INCHES	
TOLERANCES:	
FRACTIONAL ±	
ANGULAR: MACH ±	BEND ±
TWO PLACE DECIMAL ±	
THREE PLACE DECIMAL ±	
MATERIAL	1/4" Box Steel Tubing
FINISH	--
DO NOT SCALE DRAWING	

	NAME	DATE
DRAWN	???	??/??/????
CHECKED		
ENG APPR.		
MFG APPR.		
Q.A.		
COMMENTS:		

HDC, Inc.

# Right Frame Couple

SIZE	DWG. NO.	REV.
•		
SCALE: 1:2	WEIGHT:	SHEET 4 OF 12

REVISIONS		DATE	APPROVED
ZONE	REV.	DESCRIPTION	

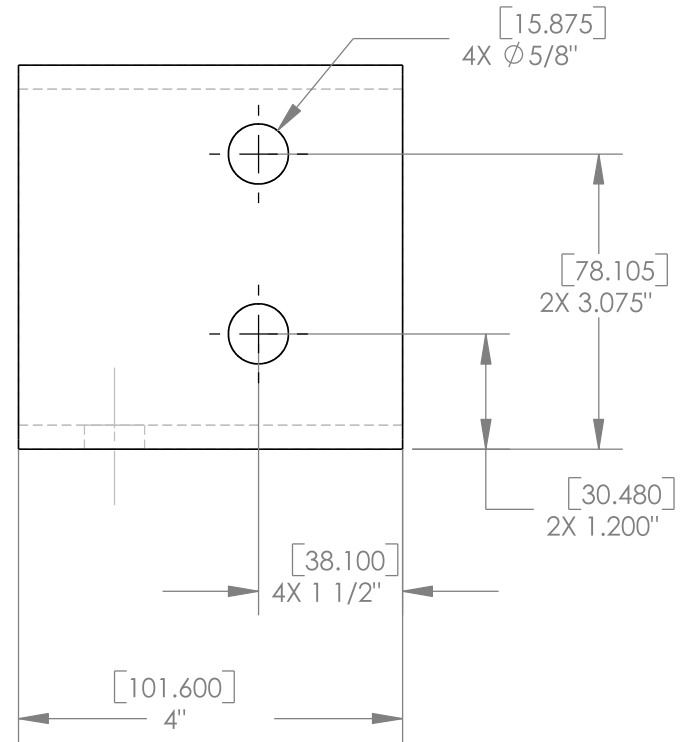
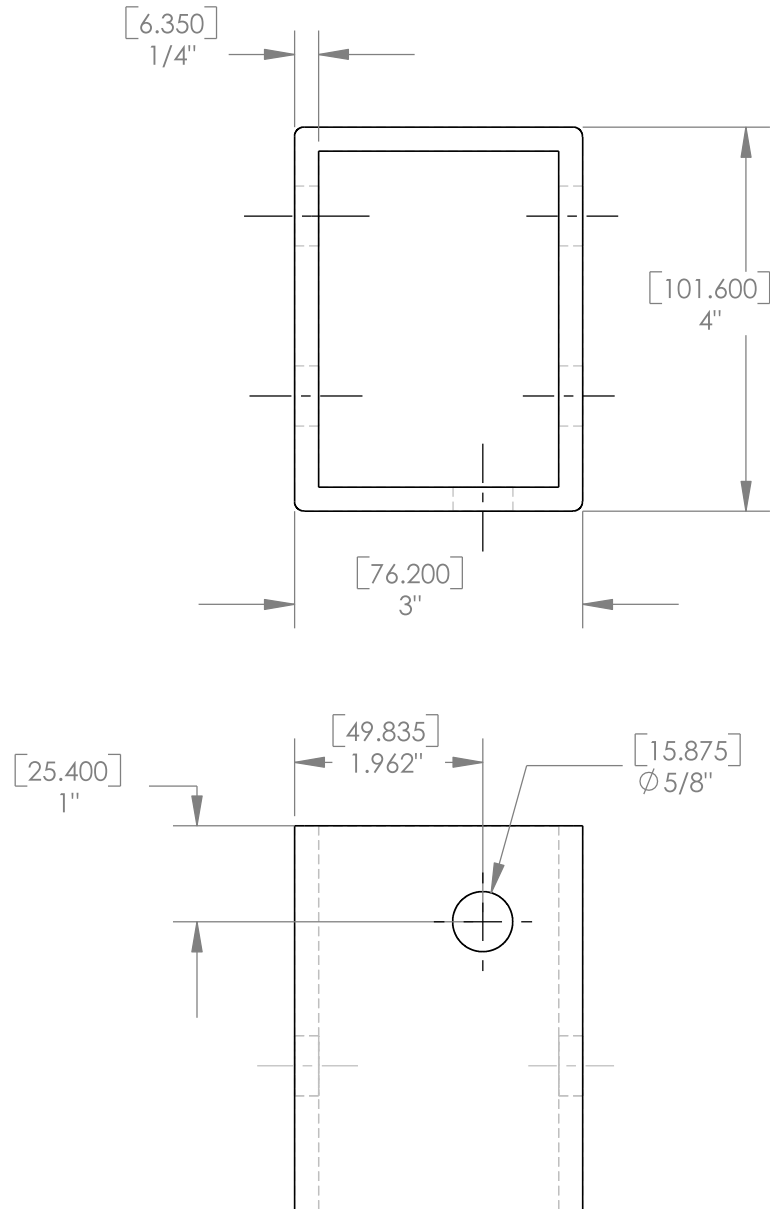

.....  
 THE INFORMATION CONTAINED IN THIS DRAWING IS THE SOLE PROPERTY OF HDC, Inc. ANY REPRODUCTION IN PART OR AS A WHOLE WITHOUT THE WRITTEN PERMISSION OF HDC, Inc. IS PROHIBITED.

DIMENSIONS ARE IN INCHES	
TOLERANCES:	
FRACTIONAL ±	
ANGULAR: MACH ± BEND ±	
TWO PLACE DECIMAL ±	
THREE PLACE DECIMAL ±	
MATERIAL	1/4" Box Steel Tubing
FINISH	--
DO NOT SCALE DRAWING	

	NAME	DATE
DRAWN	???	??/??/????
CHECKED		
ENG APPR.		
MFG APPR.		
Q.A.		
COMMENTS:		

HDC, Inc.		
Left Frame Couple		
SIZE	DWG. NO.	REV.
•		
SCALE: 1:2	WEIGHT:	SHEET 5 OF 12

REVISIONS			
ZONE	REV.	DESCRIPTION	DATE

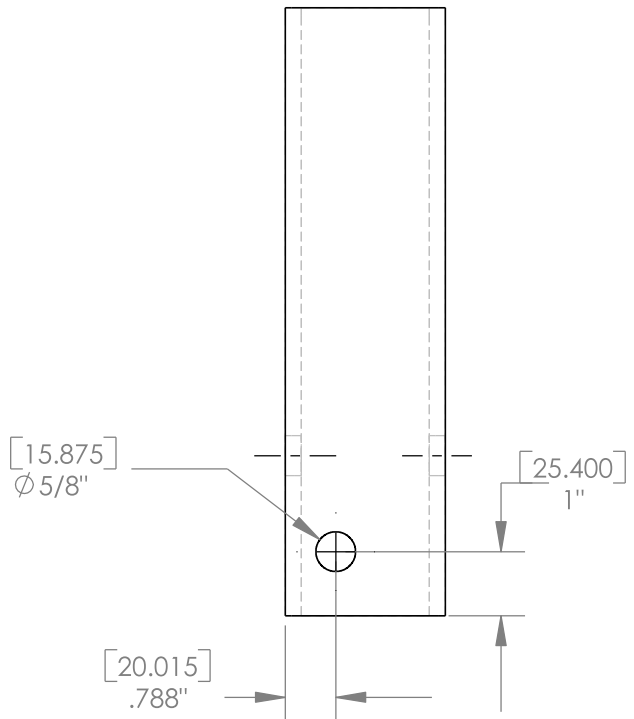
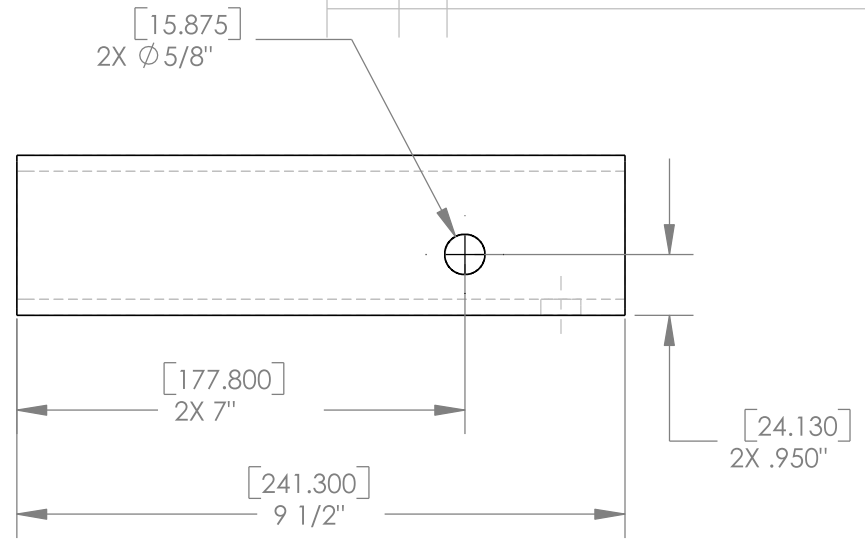
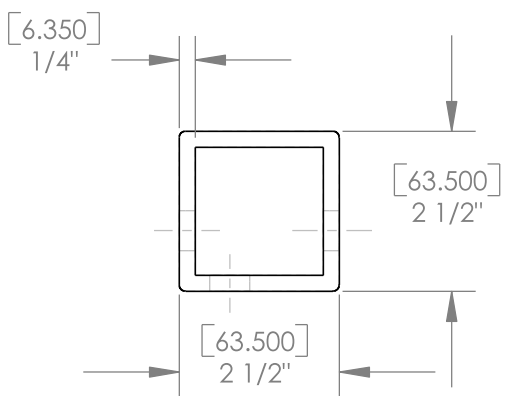

.....  
 THE INFORMATION CONTAINED IN THIS DRAWING IS THE SOLE PROPERTY OF HDC, Inc. ANY REPRODUCTION IN PART OR AS A WHOLE WITHOUT THE WRITTEN PERMISSION OF HDC, Inc. IS PROHIBITED.

DIMENSIONS ARE IN INCHES  
 TOLERANCES:  
 FRACTIONAL ±  
 ANGULAR: MACH ± BEND ±  
 TWO PLACE DECIMAL ±  
 THREE PLACE DECIMAL ±

MATERIAL  
 1/4" Square Steel Tubing

FINISH  
 --

DO NOT SCALE DRAWING

	NAME	DATE
DRAWN	???	??/??/????
CHECKED		
ENG APPR.		
MFG APPR.		
Q.A.		

COMMENTS:

HDC, Inc.

Left Frame Arm

SIZE	DWG. NO.	REV.
•		

SCALE:1:3      WEIGHT:      SHEET 6 OF 12

REVISIONS				
ZONE	REV.	DESCRIPTION	DATE	APPROVED

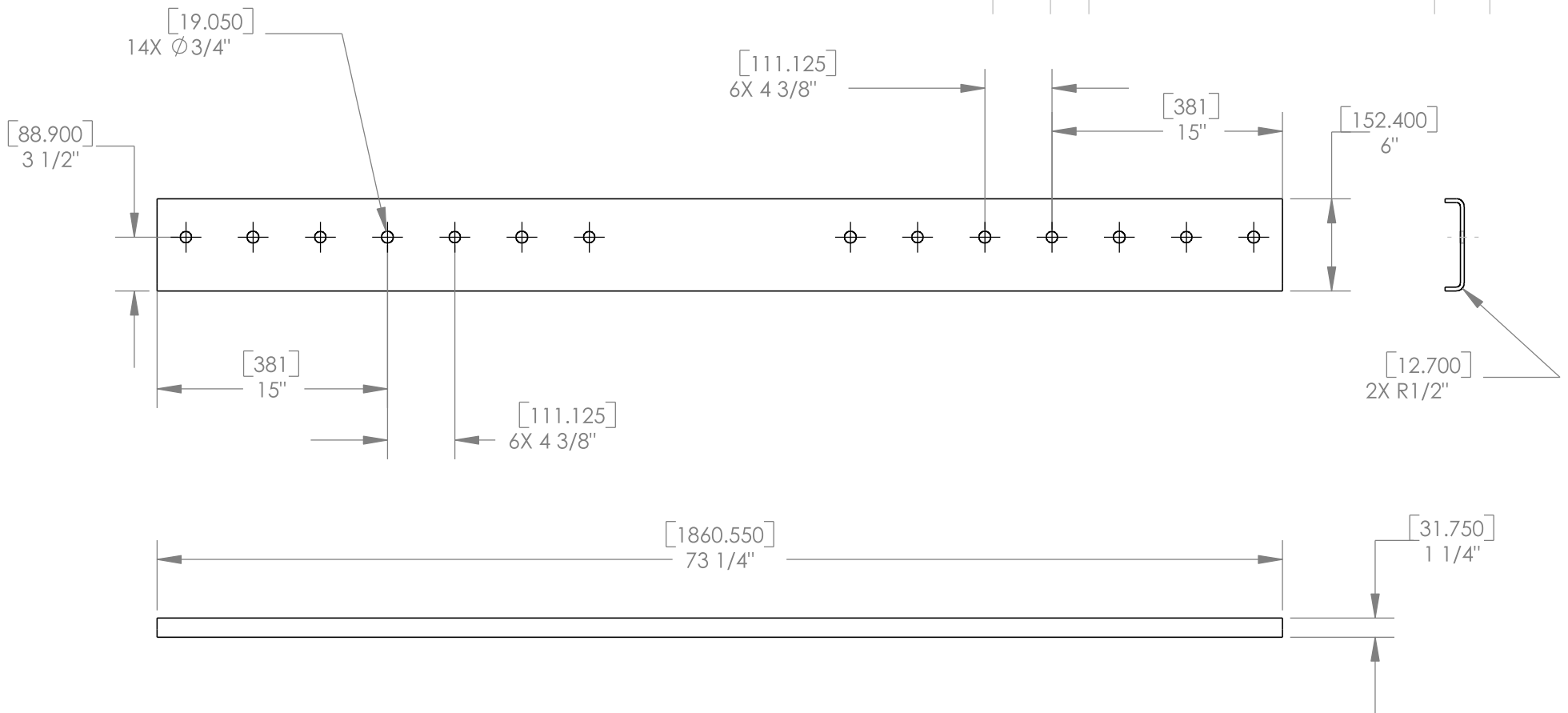

Thickness: 0.25"

.....  
 THE INFORMATION CONTAINED IN THIS DRAWING IS THE SOLE PROPERTY OF HDC, Inc. ANY REPRODUCTION IN PART OR AS A WHOLE WITHOUT THE WRITTEN PERMISSION OF HDC, Inc. IS PROHIBITED.

DIMENSIONS ARE IN INCHES		NAME	DATE
TOLERANCES:			
FRACTIONAL ±		DRAWN	CAK 09/08/2006
ANGULAR: MACH ± BEND ±		CHECKED	
TWO PLACE DECIMAL ±		ENG APPR.	
THREE PLACE DECIMAL ±		MFG APPR.	
MATERIAL		Q.A.	
1/4" Structural Channel		COMMENTS:	
FINISH			
--			
DO NOT SCALE DRAWING			

HDC, Inc.		
Backbone		
SIZE	DWG. NO.	REV.
•		
SCALE: 1:10	WEIGHT:	SHEET 7 OF 12

REVISIONS				
ZONE	REV.	DESCRIPTION	DATE	APPROVED

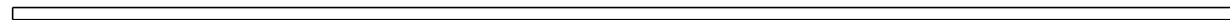
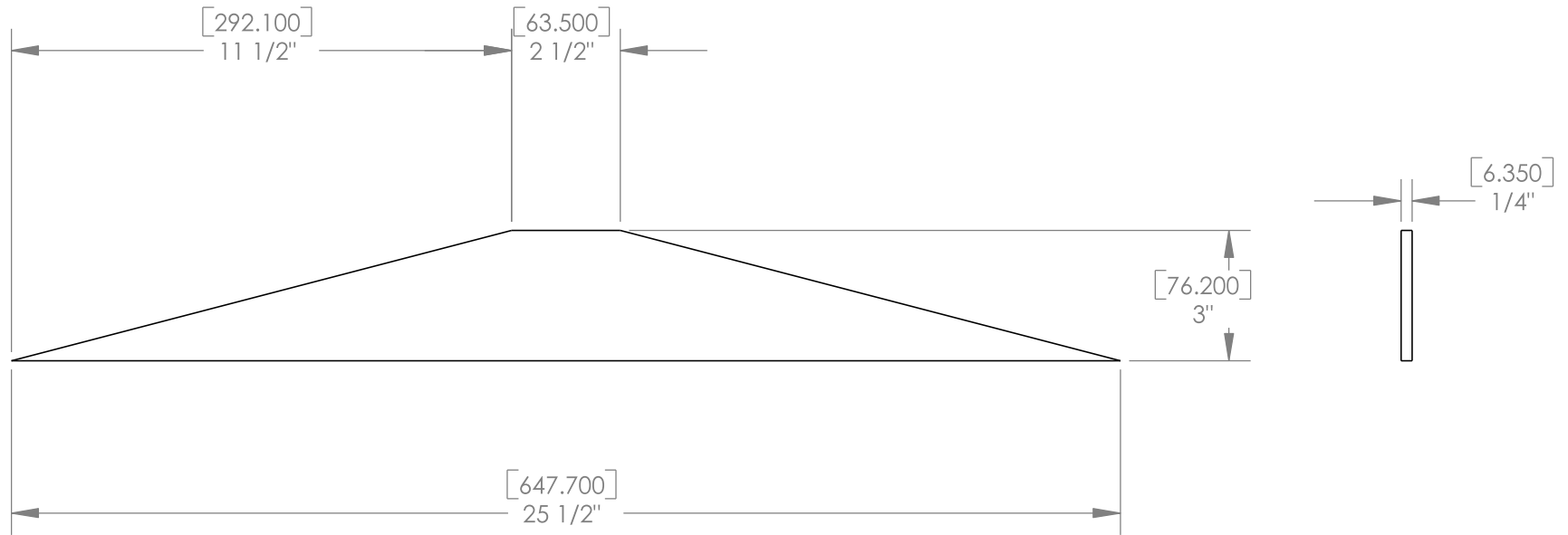

.....  
 THE INFORMATION CONTAINED IN THIS DRAWING IS THE SOLE PROPERTY OF HDC, Inc. ANY REPRODUCTION IN PART OR AS A WHOLE WITHOUT THE WRITTEN PERMISSION OF HDC, Inc. IS PROHIBITED.

DIMENSIONS ARE IN INCHES  
 TOLERANCES:  
 FRACTIONAL ±  
 ANGULAR: MACH ± BEND ±  
 TWO PLACE DECIMAL ±  
 THREE PLACE DECIMAL ±

MATERIAL  
**1/4" Flat Steel Stock**

FINISH  
 -

DO NOT SCALE DRAWING

	NAME	DATE
DRAWN	???	??/??/????
CHECKED		
ENG APPR.		
MFG APPR.		
Q.A.		
COMMENTS:		

**HDC, Inc.**

**Large Gusset**

SIZE	DWG. NO.	REV.
•		

SCALE: 1:4      WEIGHT:      SHEET 8 OF 12



		REVISIONS	DATE	APPROVED
ZONE	REV.	DESCRIPTION		

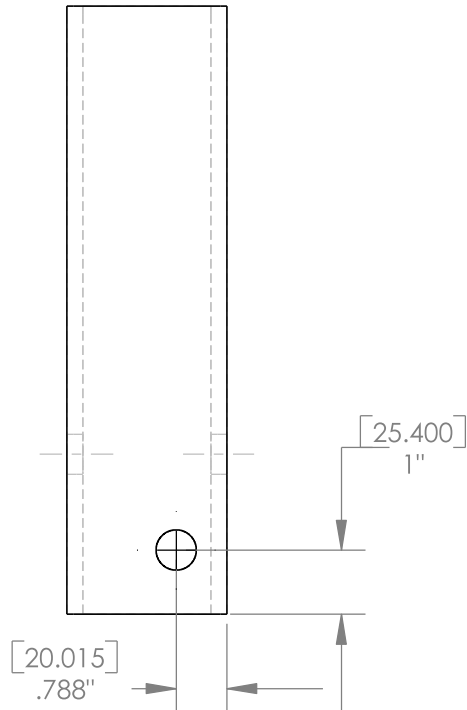
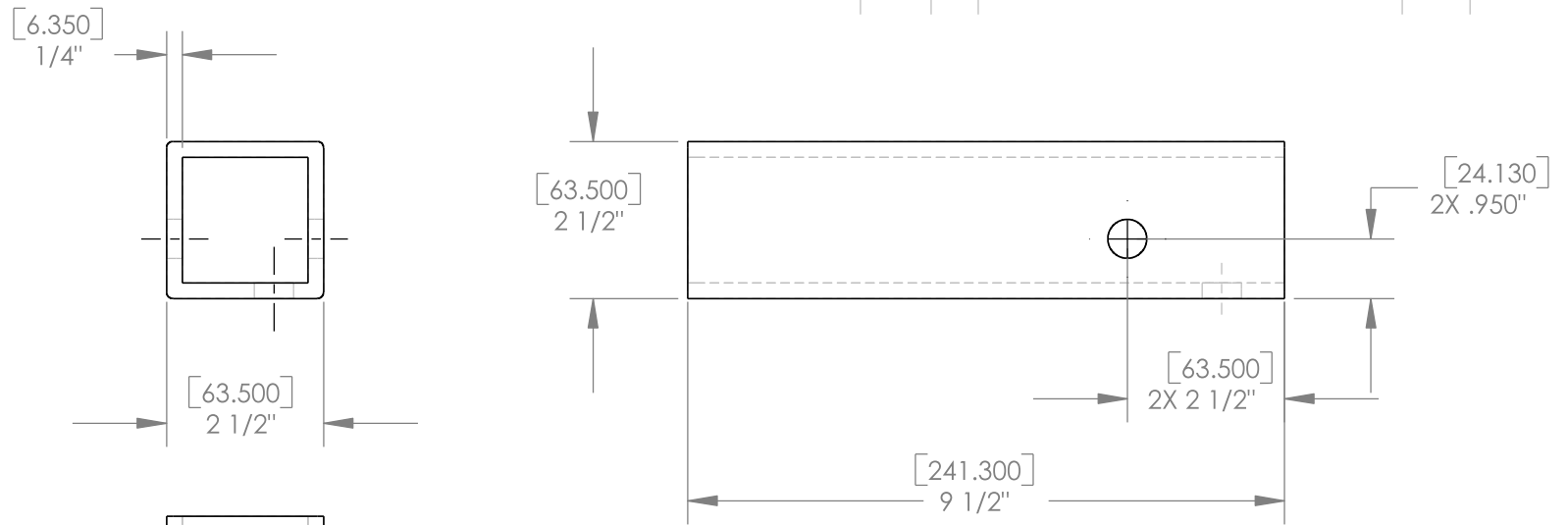

.....  
 THE INFORMATION CONTAINED IN THIS DRAWING IS THE SOLE PROPERTY OF HDC, Inc. ANY REPRODUCTION IN PART OR AS A WHOLE WITHOUT THE WRITTEN PERMISSION OF HDC, Inc. IS PROHIBITED.

DIMENSIONS ARE IN INCHES		NAME	DATE	HDC, Inc.
TOLERANCES:				
FRACTIONAL ±		DRAWN	???	Right Frame Arm
ANGULAR: MACH ± BEND ±		CHECKED	??/??/????	
TWO PLACE DECIMAL ±		ENG APPR.		
THREE PLACE DECIMAL ±		MFG APPR.		
MATERIAL		Q.A.		
FINISH		COMMENTS:		SIZE
DO NOT SCALE DRAWING				DWG. NO.
				REV.
				SCALE: 1:3
				WEIGHT:
				SHEET 9 OF 12

		REVISIONS			
ZONE	REV.	DESCRIPTION	DATE	APPROVED	

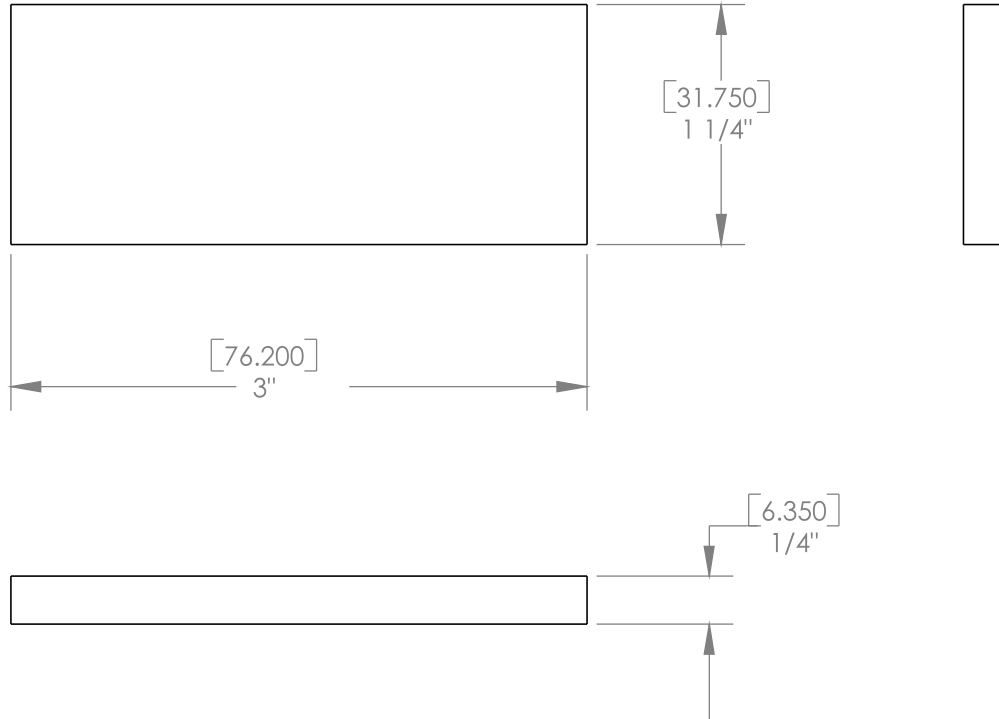

.....  
 THE INFORMATION CONTAINED IN THIS DRAWING IS THE SOLE PROPERTY OF HDC, Inc. ANY REPRODUCTION IN PART OR AS A WHOLE WITHOUT THE WRITTEN PERMISSION OF HDC, Inc. IS PROHIBITED.

DIMENSIONS ARE IN INCHES TOLERANCES: FRACTIONAL ± ANGULAR: MACH ± BEND ± TWO PLACE DECIMAL ± THREE PLACE DECIMAL ±		NAME	DATE	HDC, Inc.	
MATERIAL 1/4" Flat Steel Stock		DRAWN	???		
FINISH --		CHECKED			Box Cap
DO NOT SCALE DRAWING		ENG APPR.			
		MFG APPR.			
		Q.A.			SIZE
		COMMENTS:			DWG. NO.
					REV.
					SCALE:1:1
					WEIGHT:
					SHEET 10 OF 12

Part #	Qty	Description
7	14	5/8"-13 HHCS, 2.75" long, 1.55" thrd
8	14	5/8" Nylon Locking Nut
9	28	0.625" ID, 1.00" OD Washer
10	2	ABumper Pad
11	14	Metal Backing

REVISIONS				
ZONE	REV.	DESCRIPTION	DATE	APPROVED

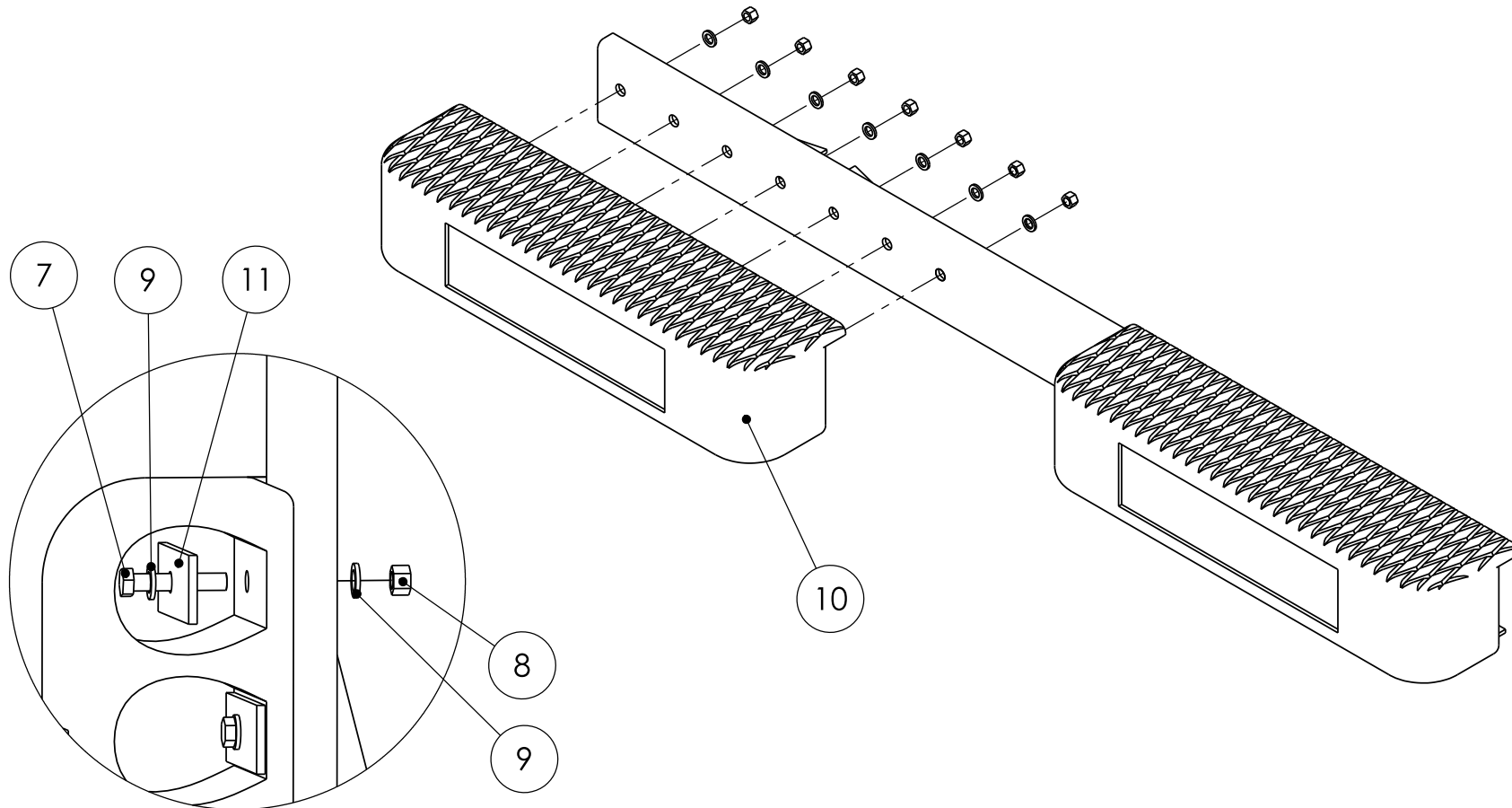

Hardware Mounting

.....  
 THE INFORMATION CONTAINED IN THIS DRAWING IS THE SOLE PROPERTY OF HDC, Inc. ANY REPRODUCTION IN PART OR AS A WHOLE WITHOUT THE WRITTEN PERMISSION OF HDC, Inc. IS PROHIBITED.

DIMENSIONS ARE IN INCHES		NAME	DATE	HDC, Inc.
TOLERANCES:		DRAWN	???	
FRACTIONAL ±		CHECKED		A-Bumper Mount
ANGULAR: MACH ± BEND ±		ENG APPR.		
TWO PLACE DECIMAL ±		MFG APPR.		
THREE PLACE DECIMAL ±		Q.A.		
MATERIAL	--	COMMENTS:		SIZE DWG. NO. REV.
FINISH	--			
DO NOT SCALE DRAWING				SCALE:1:10 WEIGHT: SHEET 11 OF 12

REVISIONS		DATE	APPROVED
ZONE	REV.	DESCRIPTION	

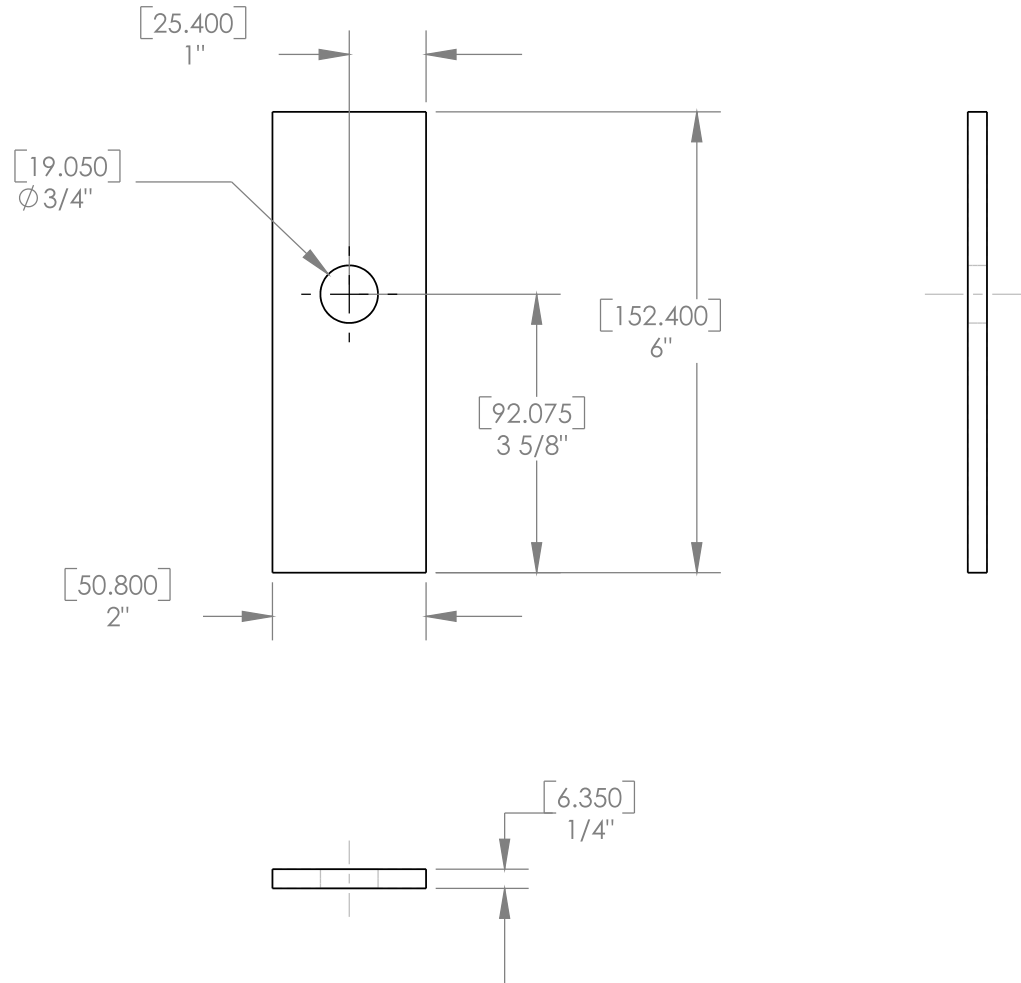

.....  
 THE INFORMATION CONTAINED IN THIS DRAWING IS THE SOLE PROPERTY OF HDC, Inc. ANY REPRODUCTION IN PART OR AS A WHOLE WITHOUT THE WRITTEN PERMISSION OF HDC, Inc. IS PROHIBITED.

DIMENSIONS ARE IN INCHES		NAME	DATE	HDC, Inc.
TOLERANCES:		DRAWN	09/11/2006	
FRACTIONAL $\pm$		CHECKED		Metal Backing
ANGULAR: MACH $\pm$ BEND $\pm$		ENG APPR.		
TWO PLACE DECIMAL $\pm$		MFG APPR.		
THREE PLACE DECIMAL $\pm$		Q.A.		
MATERIAL		COMMENTS:		SIZE
1/4" Flat Steel Stock				DWG. NO.
FINISH				REV.
--				SCALE: 1:2.5
DO NOT SCALE DRAWING				WEIGHT:
				SHEET 12 OF 12